



Step-by-step installation instructions:

1. Rid aperture of any dust.
2. Install backing rod to joint, allowing for the appropriate sealant depth as indicated below:

Joint Width (mm)	Sealant Depth (mm)
10	20
20	20
30	20
40	26

Backing rod is not necessary in horizontal joints where the top of a plasterboard-lined wall meets the underside of a concrete slab. Here the steel track serves as the backing.

3. Apply masking tape down each side of the joint, allowing for a 5mm overlap of sealant onto the substrate.
4. Apply and firmly press a bead of AGNI-Seal to each corner of the joint.
5. Once AGNI-Seal is firmly pressed into the corners of the joint, fill the remaining space down the middle of the joint with AGNI-Seal.
6. Firmly press the AGNI-Seal into the joint and smooth the surface using a sponge or spatula, ensuring that AGNI-Seal overlaps onto the substrate.
7. Remove masking tape.

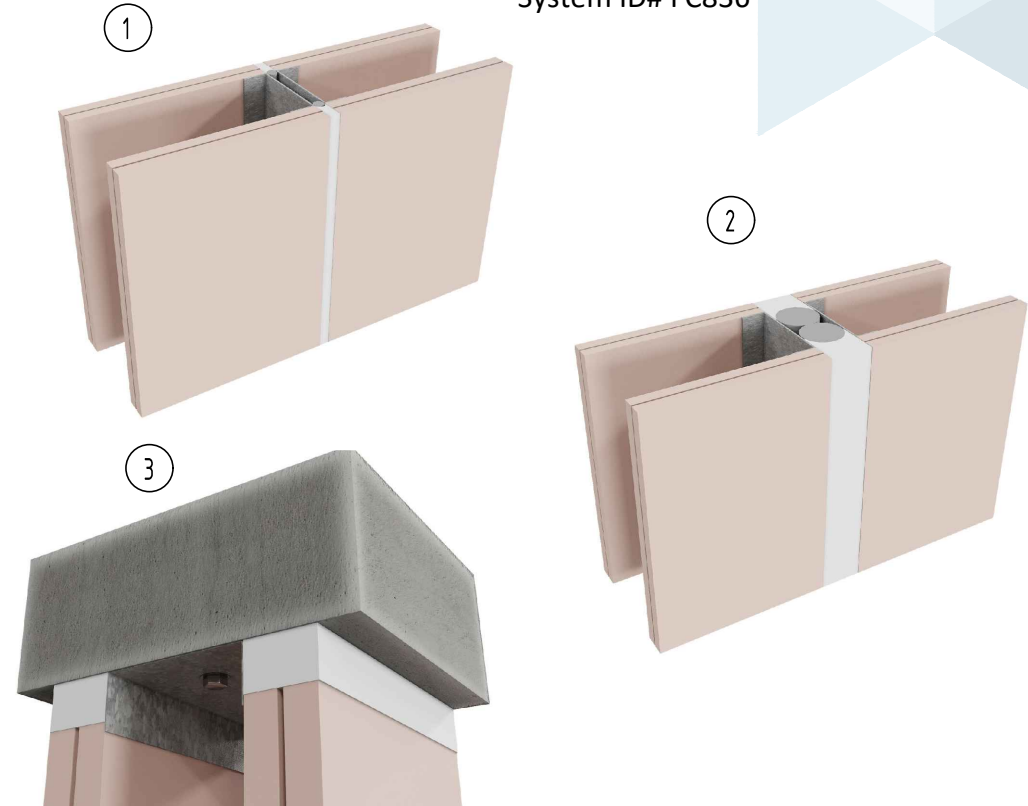

Technical Information

Substrate	<ul style="list-style-type: none"> • Min. 64mm steel or timber stud wall with a minimum of two layers of 13mm (or greater) FR plasterboard on each side, with or without insulation • Min. 116mm concrete wall 										
Joints' width & depth	<table border="0"> <tr> <td>Vertical:</td> <td>Horizontal:</td> </tr> <tr> <td>10mm x 20mm</td> <td>40mm x 26mm</td> </tr> <tr> <td>20mm x 20mm</td> <td></td> </tr> <tr> <td>30mm x 20mm</td> <td></td> </tr> <tr> <td>40mm x 26mm</td> <td></td> </tr> </table>	Vertical:	Horizontal:	10mm x 20mm	40mm x 26mm	20mm x 20mm		30mm x 20mm		40mm x 26mm	
Vertical:	Horizontal:										
10mm x 20mm	40mm x 26mm										
20mm x 20mm											
30mm x 20mm											
40mm x 26mm											
AGNI-Products	AGNI-Seal										
Protection installation	Both sides of the wall										

Compliance Information

Standards	AS1530.4-2014, AS4072.1-2005
Joints FRR/FRL	<p>Vertical:</p> <p>10mm x 20mm -/120/120</p> <p>20mm x 20mm -/120/120</p> <p>30mm x 20mm -/120/120</p> <p>40mm x 26mm -/120/120</p> <p>Horizontal:</p> <p>40mm x 26mm -/120/120</p>
Compliance reference	RIRF24008 (F-AJ-056)



Agnitek[®]
FIRE RATED TECHNOLOGY

8 Clare St Bayswater
VIC 3153, AUSTRALIA
www.agnitek.com.au

Disclaimer

Agnitek reserves the right to modify product specifications without prior notice due to its ongoing research, development & certification programme. The information in this document is provided in good faith and is intended for guidance purposes only. Any accompanying drawings are solely for illustrative purposes. Since Agnitek cannot oversee installation methods or ensure site conditions, no warranties, expressed or implied, are intended regarding the products' actual performance. We do not accept liability for any loss, damage, or injury from using this information. Please take a look at the test reports displayed on a relevant AGNI-System webpage for all compliance specifics.

Date	01.08.2024
------	------------

AGNI-Seal - Joints in Pbd or Concrete Walls
Max FRR -/120/120

System ID# FC836

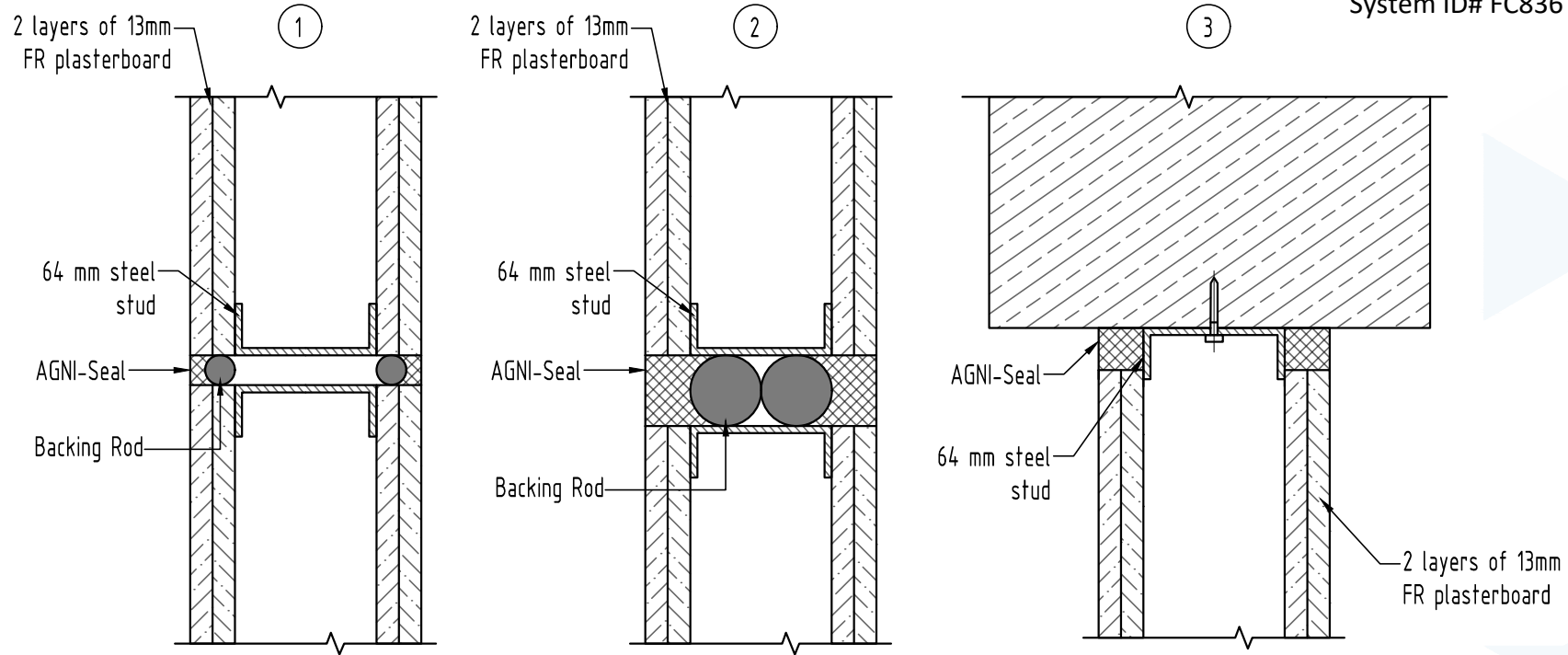

Technical Information

Substrate	<ul style="list-style-type: none"> • Min. 64mm steel or timber stud wall with a minimum of two layers of 13mm (or greater) FR plasterboard on each side, with or without insulation • Min. 116mm concrete wall
Joints' width & depth	<p>Vertical: Horizontal:</p> <p>10mm × 20mm 40mm × 26mm</p> <p>20mm × 20mm</p> <p>30mm × 20mm</p> <p>40mm × 26mm</p>
AGNI-Products	AGNI-Seal
Protection installation	Both sides of the wall

Compliance Information

Standards	AS1530.4-2014, AS4072.1-2005
Joints FRR/FRL	<p>Vertical:</p> <p>10mm × 20mm -/120/120</p> <p>20mm × 20mm -/120/120</p> <p>30mm × 20mm -/120/120</p> <p>40mm × 26mm -/120/120</p> <p>Horizontal:</p> <p>40mm × 26mm -/120/120</p>
Compliance reference	PF24008



8 Clare St Bayswater
 VIC 3153, AUSTRALIA
 www.agnitek.com.au

Disclaimer

Agnitek reserves the right to modify product specifications without prior notice due to its ongoing research, development & certification programme. The information in this document is provided in good faith and is intended for guidance purposes only. Any accompanying drawings are solely for illustrative purposes. Since Agnitek cannot oversee installation methods or ensure site conditions, no warranties, expressed or implied, are intended regarding the products' actual performance. We do not accept liability for any loss, damage, or injury from using this information. Please take a look at the test reports displayed on a relevant AGNI-System webpage for all compliance specifics.

Date	01.08.2024
------	------------